

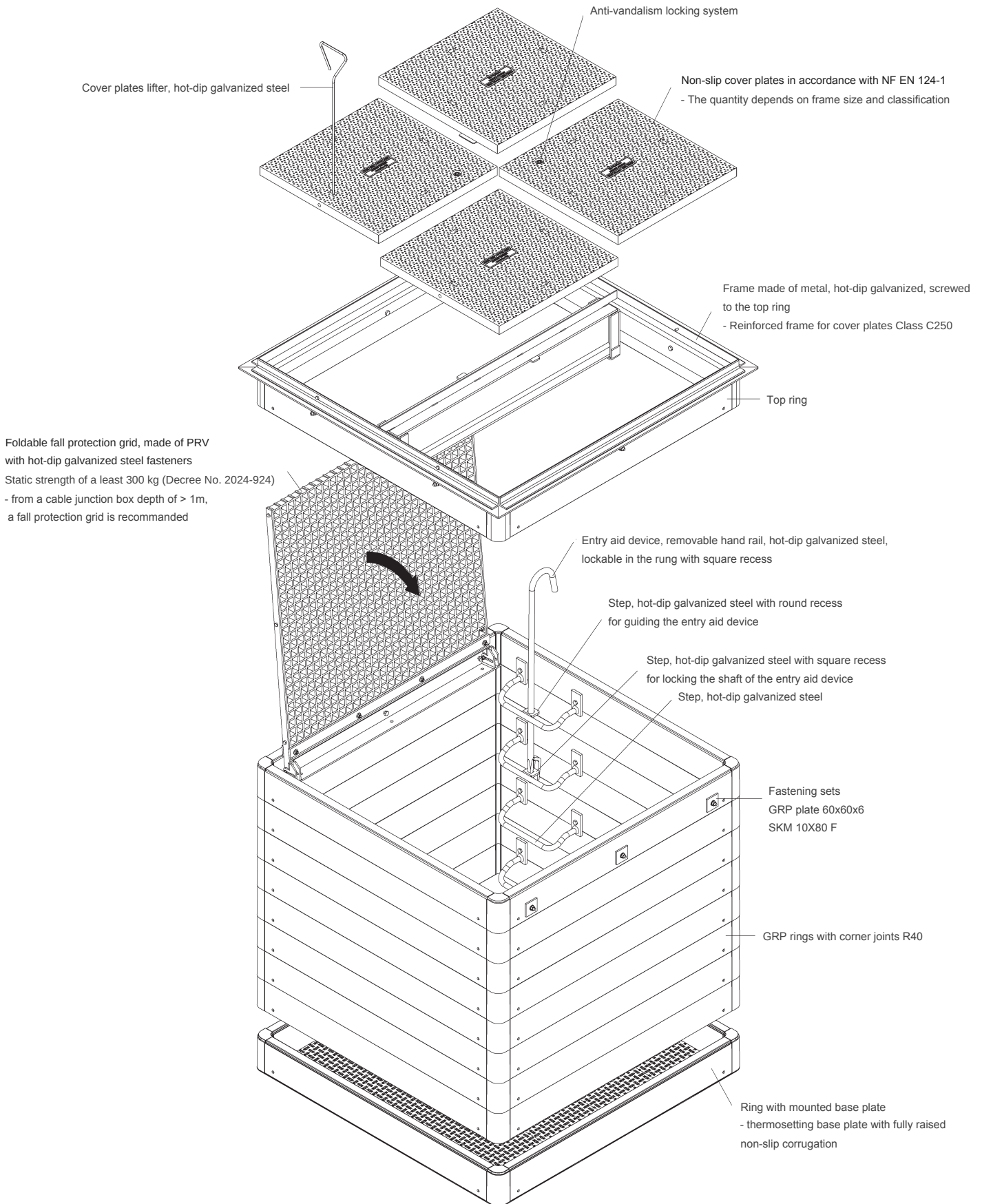

CABLE JUNCTION BOX

System overview



CABLE JUNCTION BOX

A complete range for a sustainable pit – Composite

Simple assembly for smooth installation

EBO Systems' fibreglass cable junction boxes are characterised by their high mechanical strength and light weight. The structure is completely modular and the assembly is very simple (no screws).

EBO Systems offers you a wide range of products, providing you with a composite solution, and the functionality of a fully modular chamber, adapting to your technical requirements.



Areas of application

EBO Systems' cable junction boxes are used to interconnect underground cables in new or renovated installations.

- Rail transport
- Telecommunications
- Water networks
- Public lighting

Advantages

- **10 times lighter than a concrete cable junction box**
- durable material
- simple and cost-effective assembly
- assembly without screws
- **100% recyclable**
- no sharp edges

Dimensions of the cable junction box				
Model	Usable Length (mm)	Usable Width (mm)	Outside Length (mm)	Outside Width (mm)
S1	500	500	600	600
S2	800	800	900	900
S3	1200	1200	1300	1300
S4	1900	1200	2000	1300
S5	2500	1200	2600	1300
S6	2000	600	2100	700
S6 Variant	1000	600	1100	700
S7	1000	1000	1100	1100



Installation

The cable junction box is supplied completely pre-assembled. On request, also available as a set consisting of rings, frame and cover (in individual parts). Assembly is then carried out on site. It is important to note that the individual rings must be pressed together.



1. Preparation of a stable and even subfloor.



2. Position the first ring and align it accordingly. Then stack the rings on top of each other.



3. Use a hole saw to drill the wall for the connections of the pipes. Do not drill through the lower ring.



4. Place the cover frame on the cable junction box using a suitable lifting gear.



5. Fill the excavation flush up to the frame and compact with a vibratory tamper.



6. The GRP cover plates are installed with a cable junction box lifter.

Simple assembly as a kit

To create a ring of cable junction boxes, the corner joints are connected to the pultruded profiles. Several shaft rings are stacked on top of each other to form the structure of the cable pits.

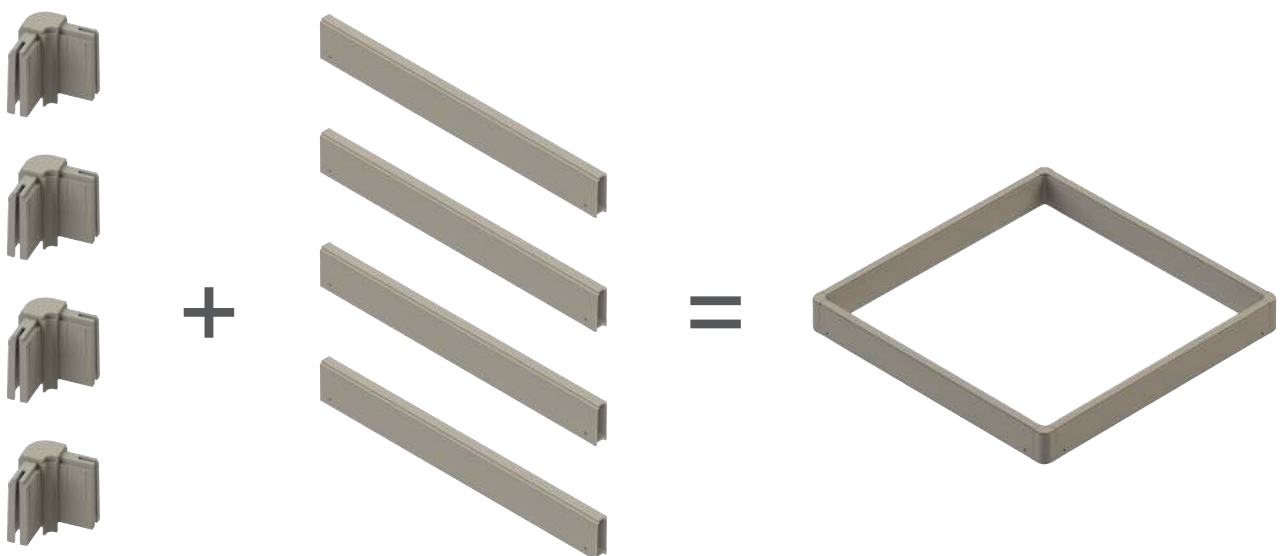

Corner Joints

pultruded Profiles

Ring

CABLE JUNCTION BOX

Cover Plates

The non-slip cover plates ensure a safe step and withstand all weather conditions.

Norm **NF EN 124-1 standard** | **R12 Norm DIN 16165**

(slip resistance value between 46 and 53).

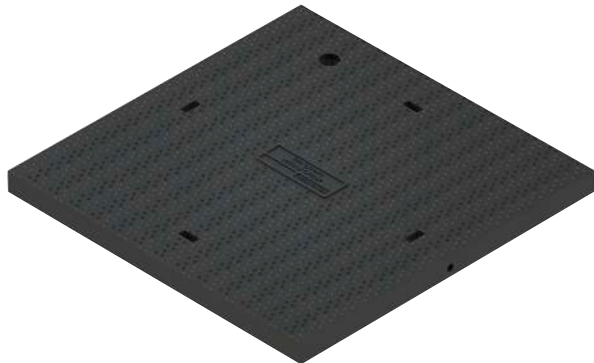

Size of the cover plates	Class
440x440x30	A15
440x440x30	B125
440x440x40	C250
645x645x30	A15
645x645x30	B125
645x645x40	C250
685x685x30	A15
685x685x30	B125
685x685x40	C250

Frame

- Frame made of metal, hot-dip galvanised with a minimum layer thickness of 70 µm
- according to standard **NF ISO 1461**
- reinforced frame for cover plates Class C250
- made to measure: The frame can be adapted to the dimensions of the cable junction box

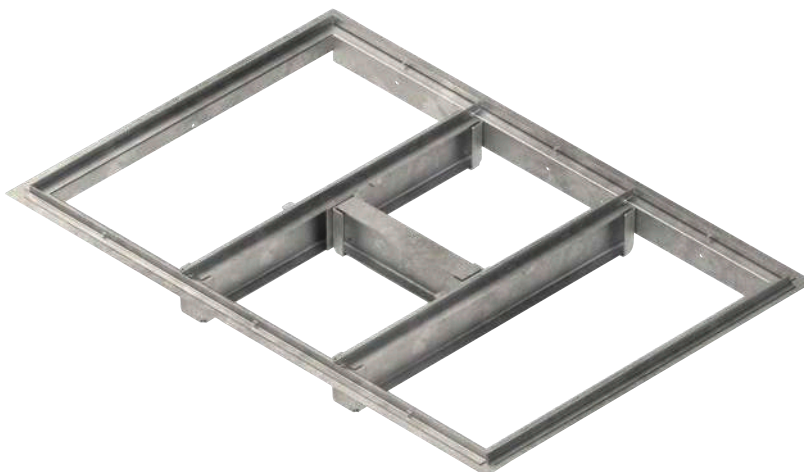

Mechanical properties

Impact resistance	At least class IK10 · Standard NF EN 62262 , with a mass of 5 kg.
Absorption of water	Non-gelling (no self-splitting of the product at -30°C) · ISO 62 < 0,3% for pultruded
Flammability	No flame spread after 60-second application of a burner flame.
Smoke toxicity	The smoke is not toxic. · ITC <0,05 (Conventional Toxicity Index, 100 times lower than tolerated)
Fatigue tests	· I&P-TL N°4319 (25 kN compression at 3 Hz with 5500 cycles)
Thermal ageing tests	Material after 5500 cycles from -30 to +70°C visually and mechanically unchanged
Bending and Compressive strength tests	· I&P-TL N°4319 · Standard NF EN 124-1 · Resistance class C250, B125, A15
Physico-chemical Properties	The cable junction box is resistant to herbicides, isooctane, petroleum and mineral oil. · NF EN ISO 175 · NF EN ISO 14125 (mechanical bending test).
UV	No change in properties due to ultraviolet rays · ISO 4582 (determination of colour change) · ISO 4892-2 (artificial ageing) · ISO 527-5 (mechanical test after ageing)

Accessories

The range offers you the possibility to adapt your cable pits to your specifications.

Fall Protection Grids

prevents the fall of goods and persons with a static strength of at least 300 kg (Decree No. 2004-924)



Step and Hand Rail

with steps and removable hand rail
NF EN 62262



Locking System

with an anti-vandalism system



Cable Junction Box Lifter

enables easy lifting of the cover plates

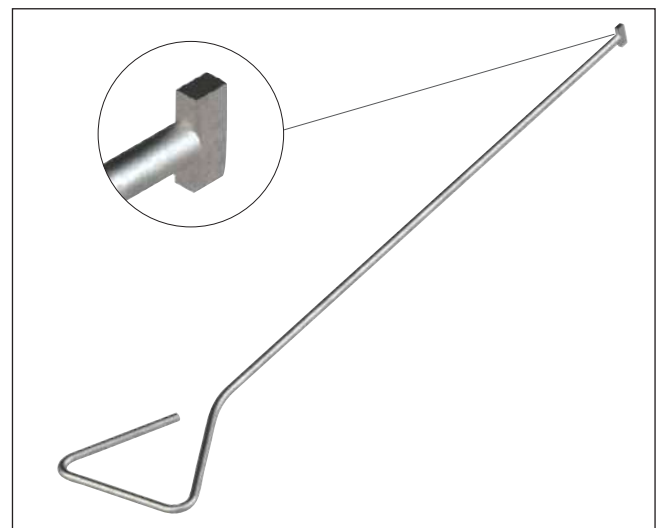

Anti-slip base plate

Thermosetting base plate with anti-slip patterns with embossed or silica surface

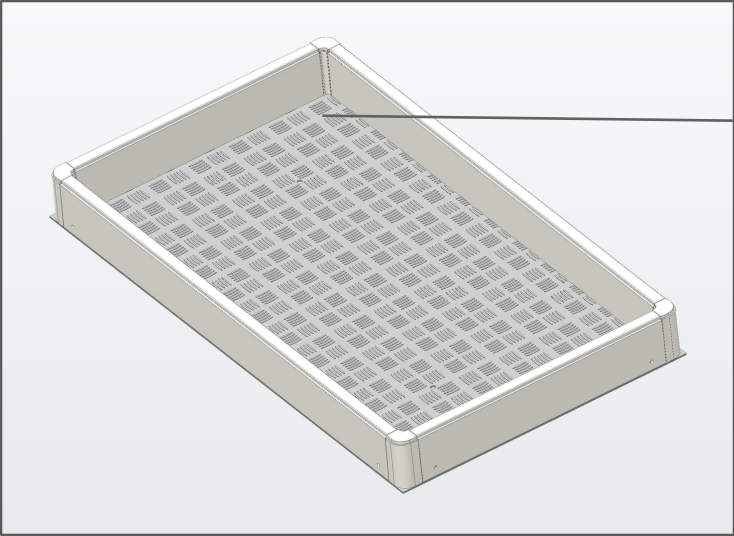

Embossed surface



Also available in silica surface

Application in water networks





EBO Systems S.A.S.
Industrial area I 5 avenue Jean Monnet
54920 Villers la Montagne/France
Tél: +33 (0)3 82 44 01 07
info@ebo-systems.com
www.ebo-systems.com